

## New York City Code Steel Emergency Lights

Pace's PAC0849 series model is designed for New York City application where a steel housing is required. The unit is designed for both initial and retrofit installations and offers high power efficiency and uniform illumination, which are ideal for stores, office, hospitals and school corridors.



### Features

- Dual-voltage input (20V/277V)
- Maintenance-free nickel-cadmium battery
- 20-gauge die-formed cold-rolled steel housing
- White corrosion-resistant polyester powder-coat paint with knock-outs for installation
- Factory-installed thermoplastic-enclosed lamp heads  
Third optional lamp head included
- Temp ratings: 10°-40° damp  
DOE Registered
- UL 924 Listed for damp location  
Master Carton Quantity 2pc

### Dimensions

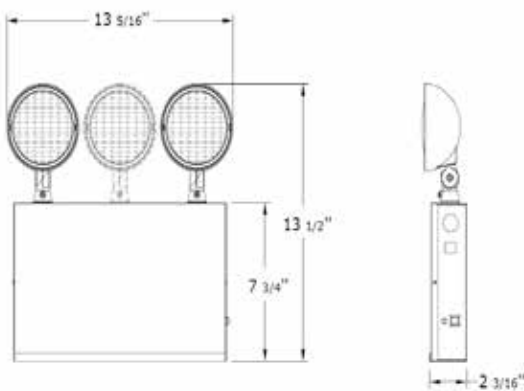

### Lumen Output

- Total Lumens: 216

### Ordering Information

SERIES	LAMPS	DESCRIPTION
PAC0849	2-9V 0.63W	Battery Backup Operation, 20-GA Steel Housing, White Finish